

The Lost Century: Dr Steven Greer's UK film premiere and conference

by Douglas Griffin

On 8 September 2024, Dr Steven Greer, the well-known American ufologist, held a conference and film premiere in London as part of his ongoing mission, running now for over 30 years, to disclose important and timely information regarding the UFO phenomenon and particularly how it pertains to so-called 'free energy'. After having already held several events this summer in a number of European cities, he was in the UK not only for the conference but also to meet with a group of governmental ministers who have shown interest in his Disclosure Project. He has garnered a huge global following for his work and is now seen as the world's leading expert on UFOs and extra-terrestrial intelligence.

Greer started the Centre for the Study of Extra-Terrestrial Intelligence (CSETI) in 1990. In 1993, he went on to found the Sirius Disclosure Project, which makes public the US Government's knowledge of UFOs, ET intelligence, and advanced energy and propulsion systems. It also encourages government and military whistle-blowers to come forward and share their 'classified information'.

The project has brought together scientists, inventors and leaders of industry across the planet as the Free Energy Movement, to advance new clean technology energy systems and enable our civilization's transition away from a dangerous over-reliance on fossil fuels.

It so happens that the symbol used for the Sirius Disclosure Project comes from a crop circle created here in the UK in 1992 at Woodborough Hill in South West England. A group, including Greer, went onto that hill one night and decided to conduct a CE-5

('close encounter of the fifth kind'), holding a specific image they had all agreed on in their minds and transmitting it to ETs, with the hope that they would create a crop circle of that symbol. The next morning one appeared in a nearby field, exactly as they had visualized: three circles connected by a line, and so it became the logo for the project.

The Lost Century: And How To Reclaim It – Greer's documentary and conference – were both an attempt to shed light on the 'unofficial' policy of governments worldwide, particularly that of the US, to cover up the fact of extra-terrestrial visitations to Earth, and the true significance of the very advanced form of technology which these spacecraft represent. This policy is in lockstep with the hidden agenda of mega-corporations like Big Oil, acting as one highly influential lobby group, and holding the great majority of us 'over a barrel' (pardon the pun) for well over 100 years. In effect, it has gamed the global economic system, with the help of said governments, only to favour its chosen form of energy production and supply for an increasingly energy-hungry world in terms of industry, transport, food production and household needs.

Running parallel with this agenda is a similarly secret US government programme involving the production of man-made UFOs, called ARVs (Alien Reproduction Vehicles), which are made by large military-industrial corporations like Raytheon, Northrop Grumman and Lockheed Martin's infamous Skunk Works. Greer himself estimates that most UFO sightings worldwide are, in fact, ARVs, which have

been fully operational since 1954!

Greer claims the manufacture of these vehicles has been the result of a reverse engineering process developed by breaking into and studying ET spacecraft retrieved from crash sites (no mean feat, considering the extraordinary metals used in UFO construction), then figuring out a way of reproducing the same propulsion mechanism. This goes right back to the 1920s, when American inventor Thomas Townsend Brown did just that and discovered a phenomenon he called 'electrogravitics', whereby the high-voltage mechanism he designed would cause a lift effect, creating, if you will, a bubble in the electromagnetic field that would allow objects to move at enormous speeds and free from the forces of gravity, in the same way UFOs do.

Greer has stated that the significance of these ET spacecraft, and the real reason for obscuring the existence of such a technology, is that they are, in effect, an "alternative energy and propulsion device", which utilises what is called the "zero-point energy field" to generate energy and a means of propulsion. The world-renowned scientist Nikola Tesla called this "radiant energy". Had he completed his mission to develop the technology he was working on in the early 1900s – technology capable of harnessing this form of energy – the world



Dr Steven Greer

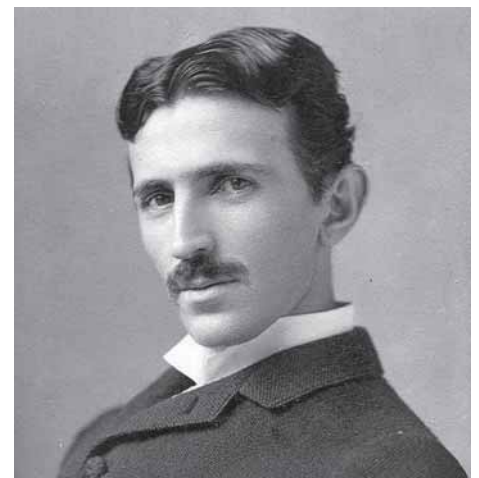

Nikola Tesla

would have been revolutionized a great many years ago, thus The Lost Century title of the documentary.

When J.P.Morgan, the famous financier and investment banker partly responsible for funding Tesla, heard of his work developing an ‘over-unity’ system – one that produces from the zero-point energy field more energy than is put into it – he thought it was ridiculous. It would be impossible to meter such a system, putting at risk his guarantee of future profits that depended on the perpetuation of a retrograde form of energy production. Tesla’s simple yet commercially devastating idea was that you could put a tap, so to speak, on these over-unity devices and extract energy for free anywhere in the world, with the right high-voltage adjustments for the particular location. J.P.Morgan made sure the project was terminated with immediate effect and went a long way to destroying Tesla’s, up until then, illustrious career.

Big Oil (ExxonMobil et al) and Big Finance (mega asset managers like BlackRock), through their stooges in unprincipled governments – the very definition of a conspiracy – have managed to put a throttlehold on the world’s energy supply. Essentially, this has enforced a ‘scarcity model’ [limited supply/high-priced demand] on us all, based on fossil fuels, eclipsing what could have been a free, clean and unlimited energy model based on zero-point universal energy.

According to Greer, a transition to free energy generation would transform life on this planet so radically that it would be unrecognisable. It could bring an end to pollution, species extinction, habitat destruction, pollution and stress-related health issues, and deal with the scourge of poverty, as the energy required to produce and transport food, etc., would be negligible – thus ushering in an era of relative peace, as many of our past and present conflicts

are in truth ‘resource wars’.

Incredible as it may seem, the earliest known example of an over-unity device was made in 1902. In that year, a US farmer and engineer, Nathan Stubblefield, built what was called the Earth Battery or Stubblefield Battery. It had rods going into the ground, some basic wiring and was “able to pick up the magnetic flux field of the planet”. As a result, this revolutionary invention was capable of drawing more energy out than was put into it. He was, in fact, running his farm from the electricity that it produced. Tesla became aware of his work and collaborated with him – there is an old, faded, black-and-white photo of them in a group portrait taken at the time.

These sophisticated instruments can tune into the zero-point field or quantum vacuum, as it is also called, and produce, in some cases, enormous amounts of energy. As one of the contributors to the documentary explained, “The seemingly empty quantum vacuum world of space is actually a roiling sea of virtual particles, fluctuating in and out of existence, and all these fluctuations require energy. If you could tap into this energy source, we would unlock a virtually unlimited source of free, clean energy.” Clearly, a group of extraordinary scientists has already figured out how to unlock this ‘hidden’ source of energy, did we but know it.

There are many such examples throughout history, but as Greer pointed out, every one of their inventions, without exception, has been stolen or destroyed. In the 1930s, American inventor T.Henry Moray created a device the size of a shoebox, which this time had no input energy at all but, once it was up and running, produced a staggering 50 kilowatts. Again, the story is all too familiar, with several attempts to assassinate Moray. In the end, he was bankrupted through nefarious means and had to shut down his laboratory and

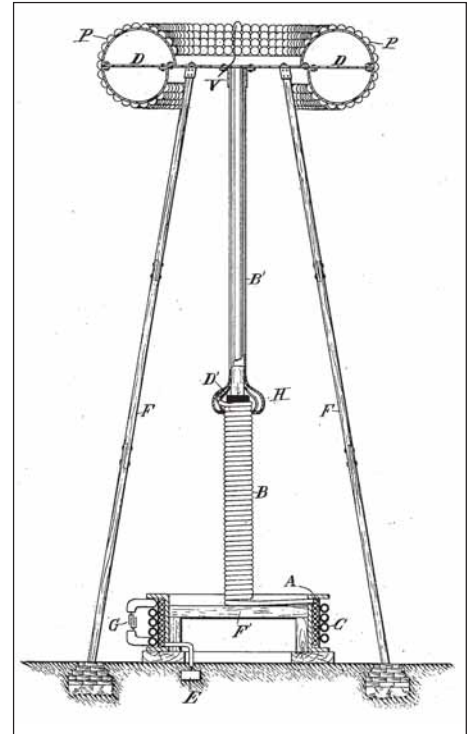

Nikola Tesla, 1907: Apparatus for transmitting electrical energy.

stop his important work. His free energy generator was shortly thereafter confiscated by ‘deep state’ agents and has not seen the light of day since.

The overarching message from Dr Greer, both in the documentary and at the conference, albeit with some dark twists and turns, conveys great hope for the future of humanity. He is a remarkable optimist considering the forces pitted against him, with a healthy instinct for telling it ‘like it is’; a self-sacrificing, courageous figure who has committed a significant portion of his life at great risk to himself and the people around him, fighting to get this crucial information into the public domain, where it deserves to be.

Despite the current hijacking of global energy systems, this new technology inevitably has to be allowed to create a ‘new world’ based not on the scarcity of fossil fuels but on the abundance of zero-point universal energy; this will be a direct result of pressure on governments worldwide from an increasingly well-informed and concerned public opinion, in part due to the tireless work of people like Dr Greer. Once the incontrovertible fact of free energy generation can no longer be denied and held back, as Dr Greer pointed out during the conference, that ‘new world’ will be ushered in relatively quickly, at least compared to the last lost century. ●

